



MELSEC-L LA1S Extension Base Unit

User's Manual

LA1S65B
LA1S68B
LA1S51B

Thank you for purchasing the Mitsubishi programmable controller MELSEC-L series.
Prior to use, please read this and relevant manuals thoroughly to fully understand the product.

MODEL	LA1SNNB-U
MODEL CODE	13J297
IB(NA)-0800541-B(1806)MEE	

SAFETY PRECAUTIONS

(Read these precautions before using this product.)

Before using this product, please read this manual and the relevant manuals carefully and pay full attention to safety to handle the product correctly.

In this manual, the safety precautions are classified into two levels: "⚠ WARNING" and "⚠ CAUTION".



WARNING

Indicates that incorrect handling may cause hazardous conditions, resulting in death or severe injury.



CAUTION

Indicates that incorrect handling may cause hazardous conditions, resulting in minor or moderate injury or property damage.

Under some circumstances, failure to observe the precautions given under "⚠ CAUTION" may lead to serious consequences.

Observe the precautions of both levels because they are important for personal and system safety.

Make sure that the end users read this manual and then keep the manual in a safe place for future reference.

[Design Precautions]



WARNING

- When setting up the system, do not allow any empty slot on the base unit. If any slot is left empty, be sure to use a blank cover (A1SG60) or a dummy module (A1SG62) for it. In addition, when using the LA1S51B model of the LA1S extension base unit, attach the included dustproof cover to the module. Otherwise, when a short circuit test is conducted or an overcurrent or overvoltage is inadvertently applied to an external I/O part, internal components of the module may jump out to the outside.
- When the programmable controller detects an abnormal condition, it stops the operation and all outputs are:

	L series module	AnS series module
Overcurrent or overvoltage protection of the power supply module is activated.	All outputs are turned off	All outputs are turned off
The CPU module detects an error such as a watchdog timer error by the self-diagnostic function.	All outputs are held or turned off according to the parameter setting.	All outputs are turned off

All outputs may be turned on if an error occurs in a part, such as an I/O control part, where the programmable controller CPU cannot detect any error. To ensure safety operation in such a case, provide a safety mechanism or a fail-safe circuit external to the programmable controller. For a fail-safe circuit example, refer to the user's manual for the CPU module used.

[Installation Precautions]

CAUTION

- Mount the module with the module fixing projection of the lower part securely inserted into the fixing hole of the base unit, and then tighten the module mounting screw within the specified torque. Improper mounting of the module or insufficient tightening of the screw can cause malfunction, failure, or drop of the module. Overtightening can damage the screw and/or module, resulting in drop, short circuit, or malfunction.

[Wiring Precautions]

CAUTION

- Do not connect the outputs of multiple power supply modules in parallel. Doing so causes the power supply modules to be overheated, resulting in a fire or failure.

For the safety precautions other than the above, refer to the manual included with the LCPU.

 Safety Guidelines

PRÉCAUTIONS DE SÉCURITÉ

(Lire ces précautions avant toute utilisation du produit.)

Avant d'utiliser ce produit, lire attentivement ce manuel ainsi que les manuels auxquels il renvoie, et toujours considérer la sécurité comme de la plus haute importance en manipulant le produit correctement.

Dans ce manuel, les précautions de sécurité sont classées en deux niveaux, à savoir : "⚠️ AVERTISSEMENT" et "⚠️ ATTENTION"



AVERTISSEMENT

Attire l'attention sur le fait qu'une négligence peut créer une situation de danger avec risque de mort ou de blessures graves.



ATTENTION

Attire l'attention sur le fait qu'une négligence peut créer une situation de danger avec risque de blessures légères ou de gravité moyennes ou risque de dégâts matériels.

Dans certaines circonstances, le non-respect d'une précaution de sécurité introduite sous le titre "⚠️ ATTENTION" peut avoir des conséquences graves.

Les précautions de ces deux niveaux doivent être observées dans leur intégralité car elles ont trait à la sécurité des personnes et aussi du système.

Veiller à ce que les utilisateurs finaux lisent ce manuel qui doit être conservé soigneusement à portée de main pour s'y référer autant que de besoin.

[Précautions lors de la conception]



AVERTISSEMENT

- Au montage du système, il ne doit rester aucune fente à carte vide sur l'unité de base. S'il reste une fente à carte vide, il est indispensable de la boucher avec un couvercle d'obturation (A1SG60) ou d'y insérer un module factice (A1SG62). De plus, si on utilise le modèle LA1S51B de l'unité de bas d'extension LA1S, protéger le module avec le couvercle pare-poussière fourni. Faute de quoi, lors d'un essai de court-circuit ou si un organe E/S externe est soumis par inadvertance à une surtension ou une surintensité, certains composants pourraient être éjectés hors du module.
- L'automate programmable suspend sa marche à la détection d'un des états suivants, l'état de sortie du système étant alors comme indiqué ci-dessous.

	Module de série L	Module de série AnS/A
La protection contre surintensité ou surtension du module d'alimentation a déclenché.	Toutes les sorties sont mises hors service.	Toutes les sorties sont mises hors service.
Le module CPU détecte une erreur, telle qu'une erreur d'horloge de surveillance détectée par la fonction d'autodiagnostic.	Toutes les sorties sont maintenues ou mises hors service en fonction du paramétrage.	Toutes les sorties sont mises hors service.

Toutes les sorties risquent de rester actives après survenance d'une erreur à un emplacement, comme un dispositif de commande d'entrée/sortie, pour lequel la CPU de l'automate programmable ne peut pas détecter les erreurs. Pour garantir la sécurité en exploitation dans un telle éventualité, il faut donc prévoir un mécanisme de sécurité ou un circuit de mise en sécurité à l'extérieur de l'automate programmable. On trouvera des exemples de circuits de mise en sécurité dans le manuel de l'utilisateur du module CPU utilisé.

[Précautions d'installation]

ATTENTION

- *Pour la mise en place du module, introduire l'ergot de maintien du bas du module à fond dans le trou de fixation sur l'unité de base, puis serrer la vis de fixation du module au couple prescrit. Un montage incorrect du module ou un serrage insuffisant de la vis peuvent être à l'origine d'un dysfonctionnement, d'une panne ou de la chute du module. Un serrage excessif peut endommager les vis et/ou le module, avec aussi un risque de chute, de court-circuits et de dysfonctionnements.*

[Précautions de câblage]

ATTENTION

- *Ne pas raccorder les sorties de plusieurs modules d'alimentation en parallèle. Cela pourrait entraîner une surchauffe des modules d'alimentation et être à l'origine d'un départ de feu ou d'une panne.*

Pour les précautions de sécurité autres que celles rappelées ci-dessus, voir le manuel fourni avec la LCPU.

 *Safety Guidelines (directive de sécurité)*

CONDITIONS OF USE FOR THE PRODUCT

- (1) Mitsubishi programmable controller ("the PRODUCT") shall be used in conditions;
- where any problem, fault or failure occurring in the PRODUCT, if any, shall not lead to any major or serious accident; and
 - where the backup and fail-safe function are systematically or automatically provided outside of the PRODUCT for the case of any problem, fault or failure occurring in the PRODUCT.
- (2) The PRODUCT has been designed and manufactured for the purpose of being used in general industries.
- MITSUBISHI SHALL HAVE NO RESPONSIBILITY OR LIABILITY (INCLUDING, BUT NOT LIMITED TO ANY AND ALL RESPONSIBILITY OR LIABILITY BASED ON CONTRACT, WARRANTY, TORT, PRODUCT LIABILITY) FOR ANY INJURY OR DEATH TO PERSONS OR LOSS OR DAMAGE TO PROPERTY CAUSED BY THE PRODUCT THAT ARE OPERATED OR USED IN APPLICATION NOT INTENDED OR EXCLUDED BY INSTRUCTIONS, PRECAUTIONS, OR WARNING CONTAINED IN MITSUBISHI'S USER, INSTRUCTION AND/OR SAFETY MANUALS, TECHNICAL BULLETINS AND GUIDELINES FOR THE PRODUCT.
- ("Prohibited Application")
- Prohibited Applications include, but not limited to, the use of the PRODUCT in;
- Nuclear Power Plants and any other power plants operated by Power companies, and/or any other cases in which the public could be affected if any problem or fault occurs in the PRODUCT.
 - Railway companies or Public service purposes, and/or any other cases in which establishment of a special quality assurance system is required by the Purchaser or End User.
 - Aircraft or Aerospace, Medical applications, Train equipment, transport equipment such as Elevator and Escalator, Incineration and Fuel devices, Vehicles, Manned transportation, Equipment for Recreation and Amusement, and Safety devices, handling of Nuclear or Hazardous Materials or Chemicals, Mining and Drilling, and/or other applications where there is a significant risk of injury to the public or property.
- Notwithstanding the above, restrictions Mitsubishi may in its sole discretion, authorize use of the PRODUCT in one or more of the Prohibited Applications, provided that the usage of the PRODUCT is limited only for the specific applications agreed to by Mitsubishi and provided further that no special quality assurance or fail-safe, redundant or other safety features which exceed the general specifications of the PRODUCTS are required. For details, please contact the Mitsubishi representative in your region.

CONTENTS

SAFETY PRECAUTIONS	1
CONDITIONS OF USE FOR THE PRODUCT	5
COMPLIANCE WITH EMC AND LOW VOLTAGE DIRECTIVES	8
ABOUT MANUALS	9
TERMS	10
1 OVERVIEW	11
1.1 About This Manual	11
1.2 About the LA1S Extension Base Unit	11
1.3 Packing List	12
1.4 Related Products (Sold Separately)	12
2 SYSTEM CONFIGURATION	13
2.1 System Configuration Using the LA1S Extension Base Unit	13
System configuration before replacement	13
System configuration after replacement	13
Where to mount the MELSEC-L series branch module	16
2.2 Configuration Devices	17
Modules compatible with the LA1S extension base unit	17
LCPUs and programming tool compatible with the LA1S extension base unit	18
2.3 Restrictions	19
3 SPECIFICATIONS	20
3.1 General Specifications	20
3.2 Performance Specifications	20
4 PART NAMES AND SETTINGS	21
4.1 Part Names	21
4.2 Extension Level Setting	22
5 MOUNTING AND INSTALLATION	23
5.1 Installing and Removing the LA1S Extension Base Unit	23
Precautions for use	23
Precautions for extension and connection	23
5.2 Precautions at Power-on	24
6 TROUBLESHOOTING	25
6.1 Checking Error Details	25
6.2 Error Codes	26
7 DIFFERENCES BETWEEN MELSEC-AnS/QnAS SERIES AND MELSEC-L SERIES	30
7.1 I/O Assignment	30
7.2 Interrupt	31
8 EXTERNAL DIMENSIONS	33
8.1 LA1S65B	33

8.2	LA1S68B	33
8.3	LA1S51B	34
	REVISIONS	35
	WARRANTY	37

COMPLIANCE WITH EMC AND LOW VOLTAGE DIRECTIVES

■ Method of ensuring compliance

To ensure that Mitsubishi programmable controllers maintain EMC and Low Voltage Directives when incorporated into other machinery or equipment, certain measures may be necessary. Please refer to the manual included with MELSEC-AnS/QnAS series modules or MELSEC-L series CPU modules.

The CE mark on the side of the programmable controller indicates compliance with EMC and Low Voltage Directives.

■ Additional measures

To ensure that this product maintains EMC and Low Voltage Directives, please refer to the manual included with MELSEC-L series CPU modules.

ABOUT MANUALS

Manuals listed below are related to this product.

Please request them as necessary with reference to this table.

- Relevant manuals

Manual name [manual number]	Available form
MELSEC-L CPU Module User's Manual (Hardware Design, Maintenance and Inspection) [SH-080890ENG]	Print book e-Manual EPUB PDF
MELSEC-L CPU Module User's Manual (Function Explanation, Program Fundamentals) [SH-080889ENG]	Print book e-Manual EPUB PDF
MELSECNET, MELSECNET/B Local Station Data Link Module User's Manual [SH-080670ENG]	Print book PDF
Transition from MELSEC-AnS/QnAS (Small Type) Series to L Series Handbook (Fundamentals) [L08258ENG]	Print book PDF

TERMS

Unless otherwise specified, this manual uses the following terms.

Term	Description
Branch module	The abbreviation for the MELSEC-L series branch module. This module serves to establish a connection to a base unit or a MELSEC-L series extension module positioned at the lower level.
Extension module	The abbreviation for the MELSEC-L series extension module. This module serves to establish a connection to a MELSEC-L series branch module.
END cover	A cover to be attached to the right side of the rightmost MELSEC-L series module
LCPU	Another term for the MELSEC-L series CPU module
CPU module	
Programming tool	A generic term for GX Works2 and GX Developer
GX Works2	The product name of the software package for the MELSEC programmable controllers
GX Developer	
Main block	A block on which the LCPU is mounted, under the MELSEC-L series
Extension block	A block on which an extension module is mounted, under the MELSEC-L series

1 OVERVIEW

1.1 About This Manual

This manual describes how to use the LA1S extension base unit and how to configure the system.

1.2 About the LA1S Extension Base Unit

The LA1S extension base unit is used for the connection to a main block or an extension block of the MELSEC-L series with MELSEC-AnS/QnAS series modules mounted.

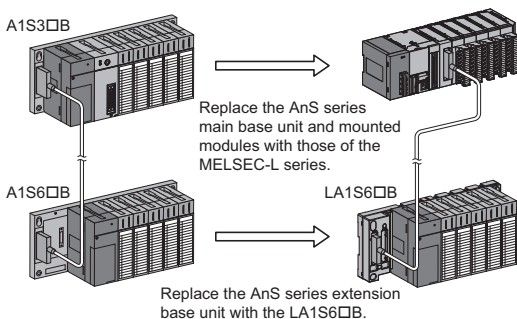

1.3 Packing List

The items listed below are packaged with this product. Before using the product, check to see that all items are included.

Item	Quantity
LA1S extension base unit	1
LA1S extension base unit installation screw (M5 × 25)	4
Dustproof cover*1	1
This manual	1

*1 The LA1S51B only includes this component in the package.

1.4 Related Products (Sold Separately)

The following table lists the products (sold separately) related to the LA1S extension base unit.

Item	Model	Remarks
DIN rail (JIS C 2812 standard)	TH35-7.5Al	This set is required only for installing the LA1S extension base unit to a DIN rail.
	TH35-7.5Fe	
	TH35-15Fe	
DIN rail fixing bracket	A1S-PLT-D	
MELSEC-L series extension cable	LC06E	This cable is required for connecting a main block or an extension block of the MELSEC-L series and the LA1S extension base unit where MELSEC-AnS/QnAS series modules are mounted.
	LC10E	
	LC30E	
GX Works2	SW1DND-GXW2-E and SW1DNC-GXW2-E	—

2 SYSTEM CONFIGURATION

2.1 System Configuration Using the LA1S Extension Base Unit

The LA1S extension base unit makes it possible to set up the following systems.

System configuration before replacement

The figure below shows the system configuration for the MELSEC-AnS series.

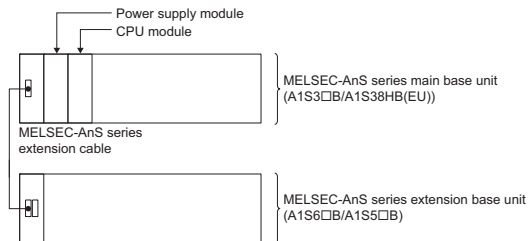

System configuration after replacement

System configuration example 1 (LA1S6□B)

The figure below shows the system configuration assuming that the main base unit part is of the MELSEC-L series and extension base units are of the MELSEC-AnS/QnAS series.

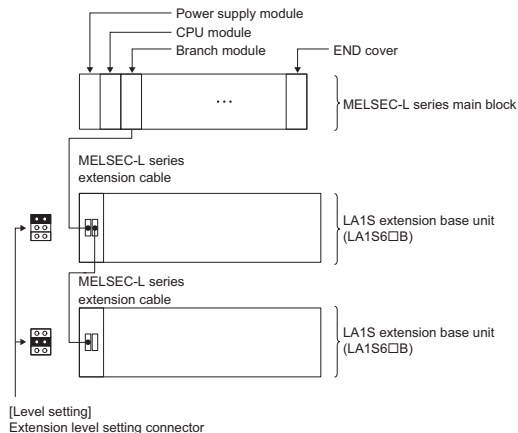

System configuration example 2 (LA1S6□B)

The figure below shows the system configuration assuming that the main base unit part is of the MELSEC-L series and extension base units are of both the MELSEC-L series and the MELSEC-AnS/QnAS series.

In setting the extension level of the LA1S extension base unit, include a MELSEC-L series extension block into the extension level as well.

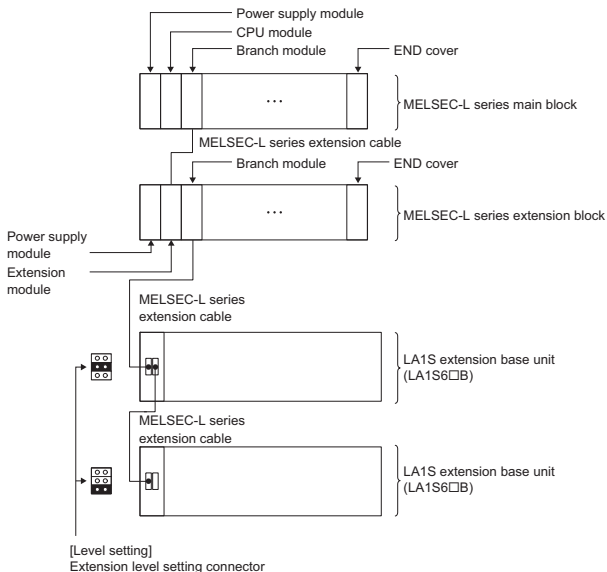

System configuration example 3 (LA1S51B)

The figure below shows the system configuration for using the LA1S51B.

The LA1S51B can be connected only at the location directly below a main block or an extension block of the MELSEC-L series.

In setting the extension level of the LA1S extension base unit, include a MELSEC-L series extension block into the extension level as well.

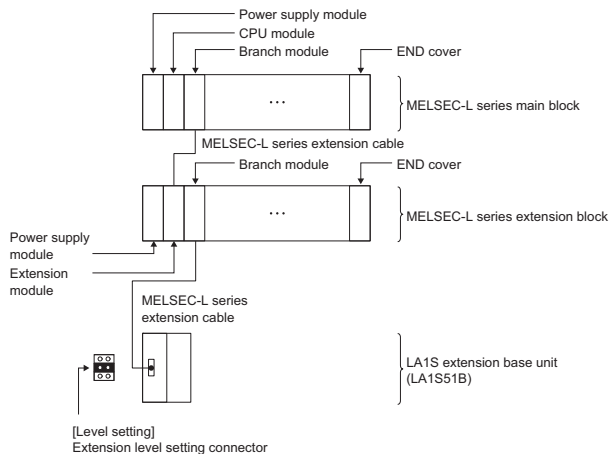

Where to mount the MELSEC-L series branch module

When the LA1S extension base unit is connected to the MELSEC-L series for use, mount the MELSEC-L series branch module at the following positions.

○: Available, ×: Not available

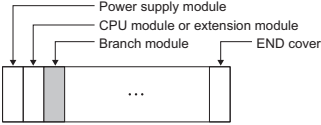
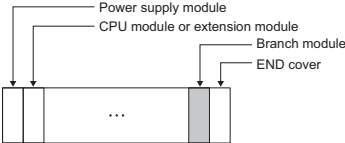
MELSEC-L series branch module	Availability	
	LA1S6□B	LA1S51B
<p>Right side of the CPU module or extension module</p>  <p>Power supply module CPU module or extension module Branch module END cover</p>	○	○
<p>Left side of the END cover</p>  <p>Power supply module CPU module or extension module Branch module END cover</p>	○	×

2.2 Configuration Devices

Modules compatible with the LA1S extension base unit

The following table lists the available modules.

Item	Model
Power supply module	A1S61PN, A1S62PN, A1S63P
Input module	A1SX10, A1SX10EU, A1SX20, A1SX20EU, A1SX30, A1SX40, A1SX40-S1, A1SX40-S2, A1SX41, A1SX41-S1, A1SX41-S2, A1SX42, A1SX42-S1, A1SX42-S2, A1SX71, A1SX80, A1SX80-S1, A1SX80-S2, A1SX81, A1SX81-S2, A1SX82-S1, A1S42X
Output module	A1SY10, A1SY10EU, A1SY14EU, A1SY18A, A1SY18AEU, A1SY22, A1SY28A, A1SY40, A1SY40P, A1SY41, A1SY41P, A1SY42, A1SY42P, A1SY50, A1SY60, A1SY60E, A1SY68A, A1SY71, A1SY80, A1SY81, A1SY82, A1S42Y
I/O module	A1SH42, A1SH42-S1, A1SX48Y58, A1SX48Y18, A1SH42P, A1SH42P-S1
High-speed counter module ^{*1}	A1SD61, A1SD62, A1SD62E, A1SD62D, A1SD62D-S1
A/D converter module	A1S64AD, A1S68AD
D/A converter module	A1S62DA, A1S68DAI, A1S68DAV
Analog I/O module	A1S63ADA, A1S66ADA
Temperature input module	A1S62RD3N, A1S62RD4N, A1S68TD
Temperature control module	A1S62TCTT-S2, A1S62TCRTBW-S2, A1S64TCTRT, A1S62TCRT-S2, A1S62TCTTBW-S2, A1S64TCTTBW, A1S64TCTT-S1, A1S64TCTTBW-S1, A1S64TCRT-S1, A1S64TCRTBW-S1
Pulse catch module	A1SP60
Analog timer module	A1ST60
Interrupt module ^{*3}	A1SI61
Positioning module ^{*1}	A1SD70 A1SD75P1-S3, A1SD75P2-S3, A1SD75P3-S3 A1SD75M1, A1SD75M2, A1SD75M3
MELSECNET/MINI-S3 master module ^{*1}	A1SJ71PT32-S3
Computer link module ^{*4}	A1SJ71UC24-R4
Intelligent communication module ^{*2}	A1SD51S
MELSECNET, MELSECNET/B local station data link module ^{*2*5}	A1SJ71AP23Q, A1SJ71AR23Q, A1SJ71AT23BQ
Paging interface module ^{*2}	A1SD21-S1
Position detection module	A1S62LS
PC fault detection module	A1SS91
Memory card interface module	A1SD59J-S2
ID interface module	A1SD35ID1, A1SD35ID2
MELSEC-I/O LINK master module	A1SJ51T64
B/NET interface module	A1SJ71B62-S3
JEMANET (OPCN-1) interface module ^{*2}	A1SJ71J92-S3
S-LINK master module	A1SJ71SL92N

Item	Model
AS-i master module	A1SJ71AS92
Blank cover	A1SG60
Dummy module	A1SG62

- *1 Dedicated instructions of the AnS/QnAS series programs are not available in the LCPU. Replace them with the FROM/TO instruction.
- *2 The total number of mounted modules labeled with this number is limited to a maximum of six.
- *3 Not available when "Interrupt input function" of the LCPU built-in I/O function is used.
- *4 Only the multidrop link function is available.
(The computer link function (dedicated protocol, nonprocedural protocol) is not available.)
- *5 The MELSECNET, MELSECNET/B local station data link module serves to connect a MELSEC-L series programmable controller as a local station in the second tier or the third tier in the MELSECNET, MELSECNET/B data link system. (L□MELSECNET, MELSECNET/B Local Station Data Link Module User's Manual)

LCPU and programming tool compatible with the LA1S extension base unit

The following versions are supported.

- LCPU: serial number first five digits "16112" or later
- GX Works2: version 1.525X or later

Point

- GX Developer, which can be used only in the L02CPU and L26CPU-BT, does not allow I/O assignment to be arbitrarily set.
- For the procedure for using programs of the MELSEC-AnS/QnAS series continuously in the MELSEC-L series, refer to the following.

L□MELSECNET, MELSECNET/B Local Station Data Link Module User's Manual

2.3 Restrictions

This section describes the restrictions when the LA1S extension base unit is used.

Restrictions when connecting the LA1S6□B

- The number of extension base units is up to two or up to three including a MELSEC-L series extension block and the LA1S extension base unit (different depending on the LCPU used).
- Extension of the MELSEC-L series is not possible after the position of the LA1S extension base unit.
- Use the extension cable with an overall cable distance of no more than 3.0m.
- GOT cannot make a bus connection to the LA1S extension base unit. Consider making a connection to an Ethernet port of the LCPU or an RS-232 adapter, an optional item.

Restrictions when connecting the LA1S51B

- The number of extension base units is up to two or up to three including a MELSEC-L series extension block and the LA1S extension base unit (different depending on the LCPU used).
- The LA1S51B can be connected only at the location directly below a main block or an extension block of the MELSEC-L series.
- Use the extension cable with an overall cable distance of no more than 3.0m. Note however that the extension cable connecting the LA1S51B and a MELSEC-L series branch module must be kept to a length of no more than 1.0m. A length of more than 1.0m does not guarantee the operation.
- Power of the LA1S51B is supplied from the power supply module on a main block or an extension block of the MELSEC-L series connected by the extension cable. Because of this, select a power supply module to be mounted so that its rated output current (5VDC) is sufficient to supply 5VDC in the LA1S51B as well.
- The MELSEC-L series branch module to be directly connected to the LA1S51B must be mounted on the right side of the LCPU or an extension module.
- The LA1S51B cannot be used in combination with the LA1S6□B.

3 SPECIFICATIONS

3.1 General Specifications

Caractéristiques principales

For details, refer to the manual included with the LCPUs.

 Safety Guidelines

Pour le détail, voir le manuel fourni avec la LCPUs.

 Safety Guidelines (directive de sécurité)

3.2 Performance Specifications

The following table shows the performance specifications of the LA1S extension base unit.

Item	Specifications			
	LA1S65B	LA1S68B	LA1S51B	
Number of mountable I/O modules	5	8	1	
Applicability of power supply module	Applicable		Not applicable	
Internal current consumption (5VDC)	150mA			
External dimensions	H	130mm		
	W	315mm	420mm	120mm
	D	38.5mm		
Weight	0.74kg	0.97kg	0.32kg	

4 PART NAMES AND SETTINGS

4.1 Part Names

The following figure and table shows the part names of the LA1S extension base unit.

■LA1S6□B

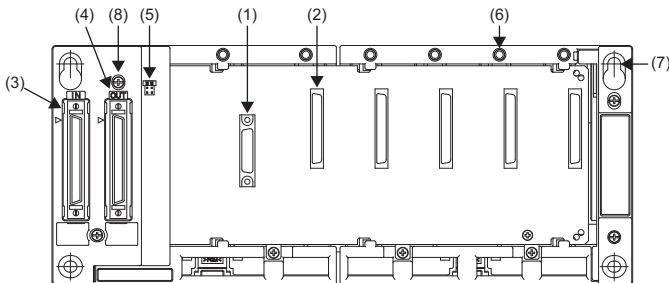

■LA1S51B

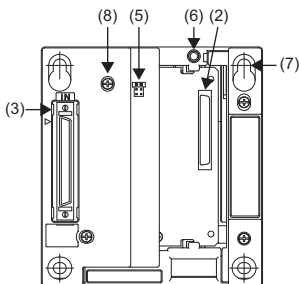



No.	Name	Application
(1)	Power supply module connector	A connector for mounting a power supply module
(2)	Module connector	A connector for mounting a module of the MELSEC-AnS/QnAS series
(3)	Extension cable connector (IN)	LA1S6□B: a connector for connecting to a base unit or MELSEC-L series branch module positioned at the upper level. LA1S51B: a connector for connecting to a MELSEC-L series branch module positioned at the upper level. A MELSEC-L series extension cable is connected here.
(4)	Extension cable connector (OUT)	A connector for connecting to a base unit positioned at the lower level. A MELSEC-L series extension cable is connected here.
(5)	Extension level setting connector	A connector for setting the number of extension base units

No.	Name	Application
(6)	Module fixing hole	A screw hole for fixing a module to the LA1S extension base unit
(7)	Base unit installation hole	A hole for installing the LA1S extension base unit to a panel including a control panel
(8)	Base cover	A protective cover for the extension cable connector. To carry out an extension, remove the base cover to set the extension level. ( Page 22 Extension Level Setting)

4.2 Extension Level Setting

Setting the extension level by means of the extension level setting connector is required for the extension base unit. Set the extension level in the following procedure:

1. The extension level setting connector of the LA1S extension base unit is located under the base cover. At first, loosen the two screws (base cover mounting screw) fixing the base cover to remove the cover from the LA1S extension base unit.
2. In accordance with the extension level, set the extension level setting connector, located on the right side of the base cover mounting screw hole on the upper side. Be careful that the extension level includes a MELSEC-L series extension block as well.

Extension level setting	Extension level		
	1st level	2nd level	3rd level
Setting of the extension level setting connector			

3. Mount the base cover on the LA1S extension base unit and tighten the screws of the base cover. ( Page 23 Precautions for use)

5 MOUNTING AND INSTALLATION

5.1 Installing and Removing the LA1S Extension Base Unit

The items below are the same as those of the MELSEC-AnS/QnAS series. (Manual of the MELSEC-AnS/QnAS series module used)

- Installing and removing the LA1S extension base unit
- Mounting modules onto the LA1S extension base unit
- Fixing to a DIN rail

The item below is the same as those of the MELSEC-L series. (MELSEC-L CPU Module User's Manual (Hardware Design, Maintenance and Inspection))

- Connecting and removing the extension cable

Precautions for use

- Before handling the module, be sure to touch a grounded metal object to discharge any static electricity from the human body. Failure to do so may cause a failure or malfunction of the module.
- Tighten the base cover mounting screw within the following torque range.

Screw	Tightening torque range
Base cover mounting screw (M3×12.5)	0.36 to 0.48N·m

Précautions d'utilisation

- *Avant de manipuler le module, toujours se débarrasser de la charge d'électricité statique dont le corps humain est porteur en touchant un objet métallique mis à la terre. Faute de quoi, il y a risque d'endommagement ou de dysfonctionnement du module.*
- *Serrer la vis de fixation du couvercle de socle au couple prescrit.*

Vis	Plage de couple de serrage
Vis de fixation du couvercle du socle (M3×12.5)	0,36 à 0,48 N·m

Precautions for extension and connection

The LA1S51B is not equipped with an extension cable connector (OUT), and so only the last slot allows a module to be mounted.

When the LA1S51B is used, the following module cannot be connected.

- LA1S6□B model of the extension base unit

On the left side of a module to be mounted on the LA1S51B, attach the included dustproof cover.

If the dustproof cover is not attached, foreign matter will enter the inner part of the module, which can cause a failure.

1. How to attach the dustproof cover

As for attaching the dustproof cover, insert it into the connector or terminal side at first, and then push the cover into place, as shown in the figure.

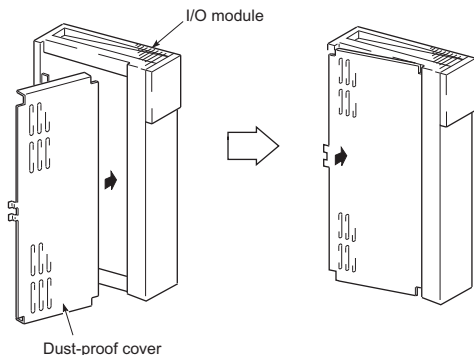

2. How to remove the dustproof cover

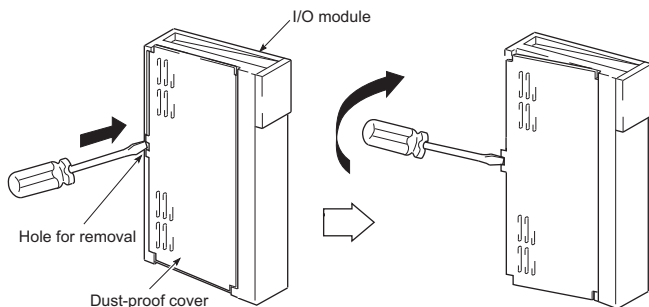

As for removing the dustproof cover, insert the tip of a flathead screwdriver into the removal hole, and then tilt the screwdriver to pry the cover off, as shown in the figure.

5.2 Precautions at Power-on

For use of the LA1S extension base unit, power to the main block and the LA1S extension base unit must be turned on in either of the following ways:

- Powering on the main block and the LA1S extension base unit simultaneously.
- Supplying power in the following order: LA1S extension base unit → main block.

6 TROUBLESHOOTING

6.1 Checking Error Details

Establishing a connection between the programming tool and the LCPU allows the check of an error detail and its cause.

If the programming tool fails to make a connection to the LCPU, check whether a problem exists in the settings of the programming tool.

 Operating manual of the programming tool used

System monitor

If the ERR.LED turns on or the module is in error, access the system monitor of the programming tool to check the error details of the module concerned, and then eliminate the cause of the error.

 [Diagnostics] ⇔ [System Monitor]

As the number of slots is displayed as "2" in the system monitor of the programming tool in checking the LA1S51B, there is no problem in using the module.

Point

If a trouble has occurred in the context of I/O assignment, check the I/O assignment number as "Start I/O" shows the current I/O assignment number.

6.2 Error Codes

This section describes error definitions and causes, and corrective actions of the LCPU in relation to the LA1S extension base unit.

For the error codes other than below, refer to the manual of the LCPU. (MELSEC-L CPU Module User's Manual (Hardware Design, Maintenance and Inspection))

Error code	Error definition and cause	Action	LED state, CPU state
1300	<p>[FUSE BREAK OFF]</p> <p>On the LA1S extension base unit, there is an output module of which fuse has blown.</p> <p>■Supplementary information</p> <ul style="list-style-type: none">• Common information: module No. (slot No.)• Individual information: - <p>■Diagnostic timing</p> <ul style="list-style-type: none">• Always	<ul style="list-style-type: none">• Check the FUSE LED of the output module and replace the lit-up module.• Readout the common information of the error by programming tool and replace the fuse of the output module corresponding to the readout number (module No.). <p>Monitoring the special registers SD1300 to SD1331 with the programming tool, replace the fuse of the module that the bit of the monitored data is "1".</p>	<p>RUN: Off/On ERR: Flashing/On</p> <p>CPU state: Stop/ Continue</p>

Error code	Error definition and cause	Action	LED state, CPU state
1711	<p>[UNIT BUS ERROR]</p> <p>With I/O assignment made in the parameters, access to the special function module fails at the time of initial communications. (At the occurrence of an error, the start I/O number of the special function module being accessed is stored into the common information.)</p> <p>■Supplementary information</p> <ul style="list-style-type: none"> • Common information: module No. (slot No.) • Individual information: - <p>■Diagnostic timing</p> <ul style="list-style-type: none"> • At power-on 	<p>Reset the CPU module and make it to a RUN state again. If the same error is still displayed, the LA1S extension base unit has failed.</p> <p>(Please consult your local Mitsubishi representative.)</p>	<p>RUN: Off</p> <p>ERR: Flashing</p> <p>CPU state: Stop</p>
1712	<p>[UNIT BUS ERROR]</p> <p>Because of a system bus error with the special function module, the FROM/TO instruction cannot be executed. (At the occurrence of an error, the program error location is stored in the individual information.)</p> <p>■Supplementary information</p> <ul style="list-style-type: none"> • Common information: module No. (slot No.) • Individual information: program error location <p>■Diagnostic timing</p> <ul style="list-style-type: none"> • At the execution of the FROM/TO instruction 		
1760	<p>[BASE UNIT ERR.]</p> <p>An error has detected in the LA1S extension base unit.</p> <p>■Supplementary information</p> <ul style="list-style-type: none"> • Common information: module No. (slot No.) • Individual information: - <p>■Diagnostic timing</p> <ul style="list-style-type: none"> • Always 		

Error code	Error definition and cause	Action	LED state, CPU state
2014	<p>[BASE LAY ERROR] A branch module connected to the block in front of the LA1S51B is mounted at the left side of the END cover.</p> <p>■Supplementary information</p> <ul style="list-style-type: none"> • Common information: module No. (slot No.) • Individual information: - <p>■Diagnostic timing</p> <ul style="list-style-type: none"> • At power-on and at reset 	<ul style="list-style-type: none"> • Change the LA1S51B to the LA1S65B or LA1S68B. • Mount the branch module connected to the LA1S51B onto the right side of the CPU module or extension module. 	<p>RUN: Off ERR: Flashing</p> <p>CPU state: Stop</p>
2102	<p>[SP.UNIT LAY ERR.] 7 or more is the total number of mounted modules consisting of MELSECNET, MELSECNET/B local station data link modules (A1SJ71AP23Q, A1SJ71AR23Q, A1SJ71AT23BQ), A/QnA intelligent communication modules (A1SD51), A/QnA JEMANET (JPCN-1) master modules (A1SJ71J92-S3), and Q/QnA paging interface modules (A1SD21-S1).</p> <p>■Supplementary information</p> <ul style="list-style-type: none"> • Common information: module No. (slot No.) • Individual information: - <p>■Diagnostic timing</p> <ul style="list-style-type: none"> • At power-on and at reset 	<ul style="list-style-type: none"> • Adjust the total number of mounted modules consisting of MELSECNET, MELSECNET/B local station data link modules, A/QnA intelligent communication modules, A/QnA JEMANET (JPCN-1) master modules, and Q/QnA paging interface modules to 6 or less. 	
2103	<p>[SP.UNIT LAY ERR.]</p> <ul style="list-style-type: none"> • An interrupt pointer specified in the built-in I/O function setting overlaps an interrupt pointer in the A1S161. • 2 or more of the A1S161 are mounted. <p>■Supplementary information</p> <ul style="list-style-type: none"> • Common information: module No. (slot No.) • Individual information: - <p>■Diagnostic timing</p> <ul style="list-style-type: none"> • At power-on and at reset 	<ul style="list-style-type: none"> • Change the setting to eliminate the overlap of interrupt pointers. • Change the number of mounted modules of the A1S161 to 1. 	
2108	<p>[SP.UNIT LAY ERR.]</p> <ul style="list-style-type: none"> • Mounted modules include the A2USCPU network module: A1SJ71LP21, A1SJ71LR21, A1SJ71BR11, A1SJ71AP21, A1SJ71AR21, or A1SJ71AT21B. • Mounted modules include the Q2ASCPU network module: A1SJ71QLP21, A1SJ71QLP21S, A1SJ71QLR21, or A1SJ71QBR11. <p>■Supplementary information</p> <ul style="list-style-type: none"> • Common information: module No. (slot No.) • Individual information: - <p>■Diagnostic timing</p> <ul style="list-style-type: none"> • At power-on and at reset 	<p>Disconnect the corresponding modules. To use the network, use CC-Link IE Field Network.</p>	

Error code	Error definition and cause	Action	LED state, CPU state
2120	<p>[SP:UNIT LAY ERR.]</p> <ul style="list-style-type: none"> • In the LA1S extension base unit, the connection order or the setting of the extension level setting connector is wrong. • In the L series modules and AnS/QnAS series modules, the assignment order of I/O numbers is wrong. <p>■Supplementary information</p> <ul style="list-style-type: none"> • Common information: - • Individual information: - <p>■Diagnostic timing</p> <ul style="list-style-type: none"> • At power-on and at reset 	<ul style="list-style-type: none"> • In the LA1S extension base unit, review the connection order and the setting of the extension level setting connector. • Set the assignment of I/O numbers at one time in the following orders: L series modules to AnS/QnAS series modules or AnS/QnAS series modules to L series modules. 	<p>RUN: Off ERR: Flashing</p> <p>CPU state: Stop</p>
2176	<p>[SYSTEM LAY ERR.]</p> <p>During the operation, an extension cable has been connected to a branch module or the LA1S extension base unit.</p> <p>■Supplementary information</p> <ul style="list-style-type: none"> • Common information: module No. (slot No.) • Individual information: - <p>■Diagnostic timing</p> <ul style="list-style-type: none"> • Always 	<p>Remove the extension cable connected during the operation.</p>	

7 DIFFERENCES BETWEEN MELSEC-AnS/QnAS SERIES AND MELSEC-L SERIES

7.1 I/O Assignment

When setting the I/O assignment, for the MELSEC-L branch module to be connected to the LA1S extension base unit, set "Type" to the branch provided for LA1S extension.

For the MELSEC-L branch module to be connected to the MELSEC-L extension module, set "Type" to "Branch".

■ System configuration example

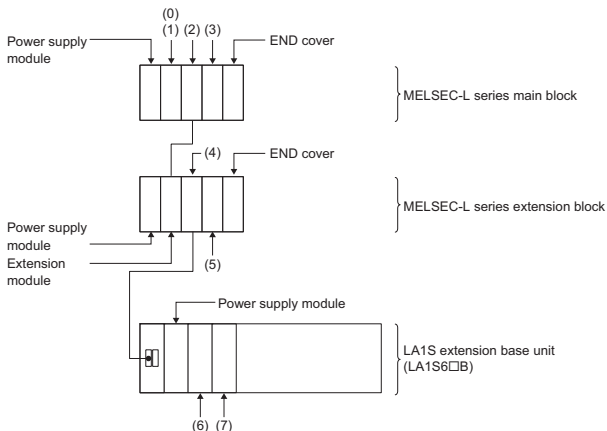

No.	Module	No.	Module	No.	Module	No.	Module
(0)	CPU module	(1)	CPU module	(2)	Branch module	(3)	Input module
(4)	Branch module	(5)	Output module	(6)	Input module	(7)	Output module

(0) to (7) correspond to the number in "No." of the "I/O Assignment" example shown below.

■ "I/O Assignment" example

Built-in Ethernet Port Setting		Built-in I/O Function Setting			Adapter Serial Setting			
PLC Name	PLC System	PLC File	PLC RAS	Boot File	Program	SFC	Device	I/O Assignment
I/O Assignment								
No.	Slot	Type	Model Name	Points	Start XY	Switch Setting		
0	PLC	PLC				Detailed Setting		
1	PLC	Built-in I/O Function		16Points	0010	Select PLC type		
2	0(*-0)	Branch				New Module		
3	1(*-1)	Input		16Points	0020			
4	2(*-2)	Branch (for LA1S Extension)						
5	3(*-3)	Output		16Points	0030			
6	4(*-4)	Input		32Points	0040			
7	5(*-5)	Output		32Points	0060			

For details on the I/O assignment, refer to the following.

□ MELSEC-L CPU Module User's Manual (Function Explanation, Program Fundamentals)

7.2 Interrupt

Modules mounted on the LA1S extension base unit can be set up to generate interrupts as described below:

- Generating interrupts with I0 to I15 assigned by employing the built-in I/O function or an interrupt module
- Generating interrupts with I16 to I27 assigned by employing a sequence activation module

The table below compares the priority order of interrupt pointers with the MELSEC-A series interrupt module mounted, and the priority order of interrupt pointers with the MELSEC-L series interrupt function used.

No.	Interrupt factor		Priority	
			With the MELSEC-L series interrupt function used*1	With the MELSEC-A series interrupt module mounted*2
I0	Interrupt by a built-in I/O function or an interrupt module	1st point	5	225
I1		2nd point	6	226
I2		3rd point	7	227
I3		4th point	8	228
I4		5th point	9	229
I5		6th point	10	230
I6		7th point	11	231
I7		8th point	12	232
I8		9th point	13	233
I9		10th point	14	234
I10		11th point	15	235
I11		12th point	16	236
I12		13th point	17	237
I13		14th point	18	238
I14		15th point	19	239
I15		16th point	20	240
I16	Interrupt by a sequence activation module	1st module	227	213
I17		2nd module	228	214
I18		3rd module	229	215
I19		4th module	230	216
I20		5th module	231	217
I21		6th module	232	218
I22		7th module	233	219
I23		8th module	234	220
I24		9th module	235	221
I25		10th module	236	222
I26		11th module	237	223
I27		12th module	238	224

No.	Interrupt factor		Priority	
			With the MELSEC-L series interrupt function used ^{*1}	With the MELSEC-A series interrupt module mounted ^{*2}
I28	Interrupt by a built-in timer	100ms	4	
I29		40ms	3	
I30		20ms	2	
I31		10ms	1	
I32 to I44	—			
I45	Multiple CPU synchronous interrupt	0.88ms	—	
I46 to I49	—			
I50 to I255	Intelligent function module interrupt	^{*3}	21 to 226	5 to 212

^{*1} Indicates the interrupt input function where the input signal Xn (n = 0 to F) is assigned to the interrupt pointers I0 to I15 by means of the built-in I/O function of the LCPU.

^{*2} Indicates MELSEC-A series interrupt modules where the interrupt pointers I0 to I15 are used for assignment.

^{*3} Set which intelligent function module to use in the PLC parameters.

8 EXTERNAL DIMENSIONS

8.1 LA1S65B

The following figure shows the external dimensions of the LA1S65B.

4 installation screws (M5×25)

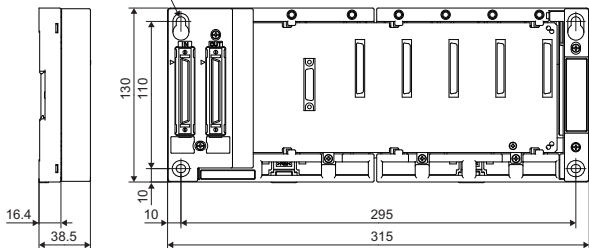

(Unit: mm)

8.2 LA1S68B

The following figure shows the external dimensions of the LA1S68B.

4 installation screws (M5×25)

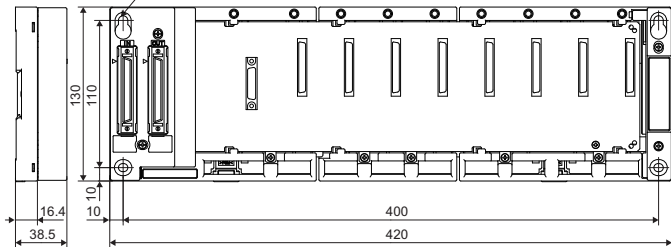

(Unit: mm)

8.3 LA1S51B

The following figure shows the external dimensions of the LA1S51B.

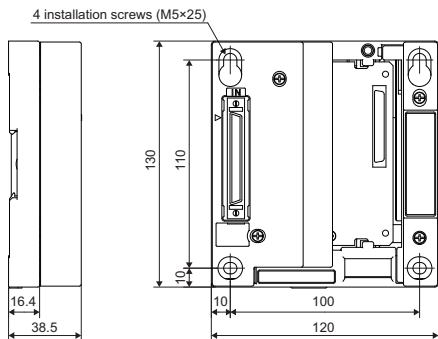

(Unit: mm)

REVISIONS

*The manual number is given on the bottom left of the back cover.

Print date	*Manual number	Description
October 2014	IB(NA)-0800541-A	First edition
June 2018	IB(NA)-0800541-B	Descriptions are revised due to compliance with the Chinese standardized law.

This manual confers no industrial property rights or any rights of any other kind, nor does it confer any patent licenses. Mitsubishi Electric Corporation cannot be held responsible for any problems involving industrial property rights which may occur as a result of using the contents noted in this manual.

© 2014 MITSUBISHI ELECTRIC CORPORATION

WARRANTY

Mitsubishi will not be held liable for damage caused by factors found not to be the cause of Mitsubishi; machine damage or lost profits caused by faults in the Mitsubishi products; damage, secondary damage, accident compensation caused by special factors unpredictable by Mitsubishi; damages to products other than Mitsubishi products; and to other duties.

Country/Region	Sales office/Tel	Country/Region	Sales office/Tel
USA	Mitsubishi Electric Automation Inc. 500 Corporate Woods Parkway, Vernon Hills, IL 60061, USA Tel : +1-847-478-2100	South Africa	CBI-Electric. Private Bag 2016, ZA-1600 Isando, South Africa Tel : +27-11-977-0770
Brazil	MELCO-TEC Representacao Comercial e Assessoria Tecnica Ltda. Av. Paulista, 1439, cj74, Bela Vista, Sao Paulo CEP: 01311-200-SP Brazil Tel : +55-11-3146-2200	China	Mitsubishi Electric Automation (China) Ltd. No.1386 Hongqiao Road, Mitsubishi Electric Automation Center, Changning District, Shanghai, China Tel : +86-21-2322-3030
Germany	Mitsubishi Electric Europe B.V. German Branch Gothaer Strasse 8, D-40880 Ratingen, Germany Tel : +49-2102-486-0	Taiwan	Setsuyo Enterprise Co., Ltd. 6F., No.105, Wugong 3rd Road, Wugu District, New Taipei City 24889, Taiwan, R.O.C. Tel : +886-2-2299-2499
UK	Mitsubishi Electric Europe B.V. UK Branch Travellers Lane, Hatfield, Hertfordshire, AL10 8XB, UK. Tel : +44-1707-27-6100	Korea	Mitsubishi Electric Automation Korea Co., Ltd. 3F, 1480-6, Gayang-Dong, Gangseo-Gu, Seoul, 157-200, Korea Tel : +82-2-3660-9530
Italy	Mitsubishi Electric Europe B.V. Italian Branch Viale Colleoni 7-20864 Agrate Brianza (Milano), Italy Tel : +39-039-60531	Singapore	Mitsubishi Electric Asia Pte, Ltd. Industrial Division 307, Alexandra Road, Mitsubishi Electric Building, Singapore, 159943 Tel : +65-6470-2308
Spain	Mitsubishi Electric Europe B.V. Spanish Branch Carretera de Rubi 76-80.AC.420, E-08190 Sant Cugat del Valles (Barcelona), Spain Tel : +34-93-565-3131	Thailand	Mitsubishi Electric Automation (Thailand) Co., Ltd. Bang-Chan Industrial Estate No.111 Soi Serithai 54, T.Kannayao, A.Kannayao, Bangkok 10230 Thailand Tel : +66-2906-3238
France	Mitsubishi Electric Europe B.V. French Branch 25, Boulevard des Bouvets, F-92741 Nanterre Cedex, France Tel : +33-1-5568-5568	Indonesia	P. T. Autoteknindo Sumber Makmur Muara Karang Selatan, Block A / Utara No.1 Kav. No. 11, Kawasan Industri Pergudangan, Jakarta-Utara 14440, P.O, Box 5045, Indonesia Tel : +62-21-663-0833
Czech Republic	Mitsubishi Electric Europe B.V.-o.s.Czech office Avenir Business Park, Radicka 751/113e, 158 00 Praha5, Czech Republic Tel : +420-251-551-470	India	Mitsubishi Electric India Pvt. Ltd. 2nd Floor, Tower A & B, Cyber Greens, DLF Cyber City, DLF Phase-III, Gurgaon-122002 Haryana, India Tel : +91-124-463-0300
Poland	Mitsubishi Electric Europe B.V. Polish Branch ul. Krakowska 50, 32-083 Balice, Poland Tel : +48-12-630-47-00	Australia	Mitsubishi Electric Australia Pty. Ltd. 348 Victoria Road PO BOX 11, Rydalmere, N.S.W 2116, Australia Tel : +61-2-9684-7777
Russia	Mitsubishi Electric Europe B.V. Russian Branch St.Petersburg office Piskarevsky pr. 2, bld 2, lit "Sch", BC "Benua", office 720; 195027, St. Petersburg, Russia Tel : +7-812-633-3497		

MITSUBISHI ELECTRIC CORPORATION

HEAD OFFICE : TOKYO BUILDING, 2-7-3 MARUNOUCHI, CHIYODA-KU, TOKYO 100-8310, JAPAN
NAGOYA WORKS : 1-14, YADA-MINAMI 5-CHOME, HIGASHI-KU, NAGOYA, JAPAN

When exported from Japan, this manual does not require application to the Ministry of Economy, Trade and Industry for service transaction permission.

Specifications subject to change without notice.